

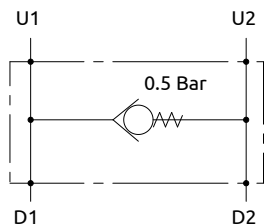

Valvola anticavitazione Anticavitation valve

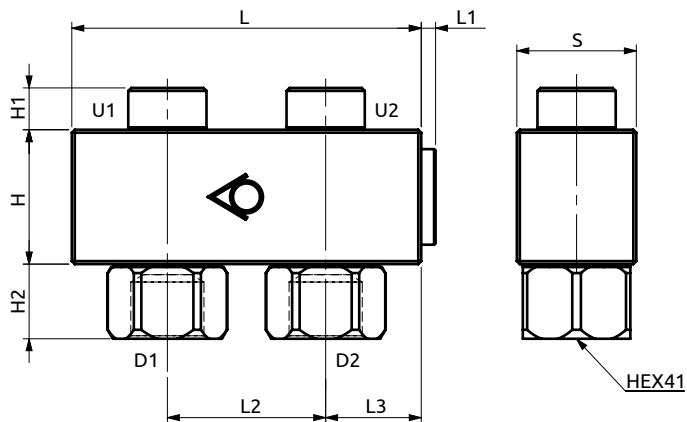

CURVE CARATTERISTICHE
PERFORMANCE CURVES

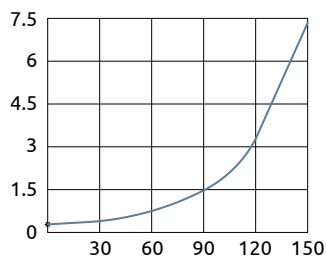

Corpo in acciaio / Steel body

A900600.02.00	117	4.8	53	32	40	45	14	25
COD.	L	L1	L2	L3	S	H	H1	H2

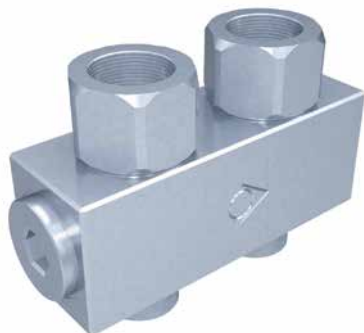

DESCRIZIONE	DESCRIPTION
Flangiabile su motori SUNFAB.	Flangeable on SUNFAB motors.

Codice Ordinazione	Pressione di Lavoro	Pressione Max	Dimensione Porte	Peso
Ordering Code	Working Pressure	Max Pressure	Port Size	Weight
A900600.02.00	320 bar	350 bar	3/4"G	2 kg