

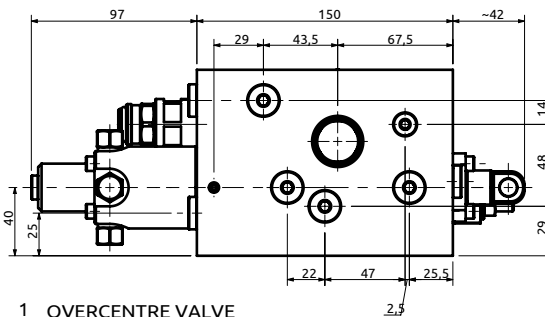

## Blocco integrato distributore e valvola rigenerativa per spaccalegna Integrated block with spool valve and regenerative system for wood splitter

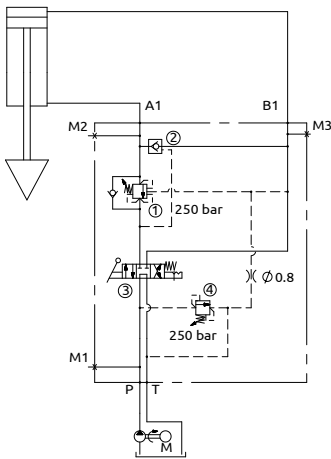

- 1 OVERCENTRE VALVE  
(CLOSED CENTRE VERSION)
- 2 PILOT OPERATED  
CHECK VALVE  
(PILOTED TO CLOSE)
- 3 DIRECTIONAL VALVE
- 4 RELIEF VALVE

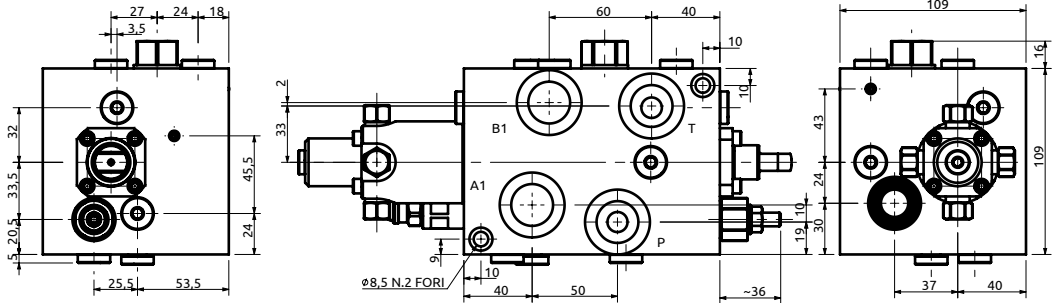

## DESCRIZIONE

La valvola permette la discesa veloce dello stelo cilindrico nella corsa a vuoto, grazie al circuito rigenerativo integrato e la piena potenza della macchina durante la fase di lavoro in cui la fase rigenerativa viene esclusa automaticamente.

## DESCRIPTION

The valve allows high speed of the cylinder, thanks to the regenerative system during the free stroke and the full power during the working stroke, when the regenerative function is automatically taken off.

Corpo in alluminio/Aluminium body

Codice Ordinazione Ordering Code	Rapporto di Pilotaggio Pilot Ratio	Campo di Taratura Pressure Range		Taratura Standard Standard Setting	Incremento per Giro Pressure Increase	Portata Massima Max Flow	Pressione Max Max Pressure	Dimensione Porte Port Size	Peso Weight
A600050.27.00	4:1	1	100-350 bar	250 bar	108 bar/turn	100 l/min	300 bar	3/4"G	5.8 kg
	2.9:1	2	-	-	-				
	-	3	-	-	-				
	-	4	50-300 bar	250 bar	65 bar/turn				