

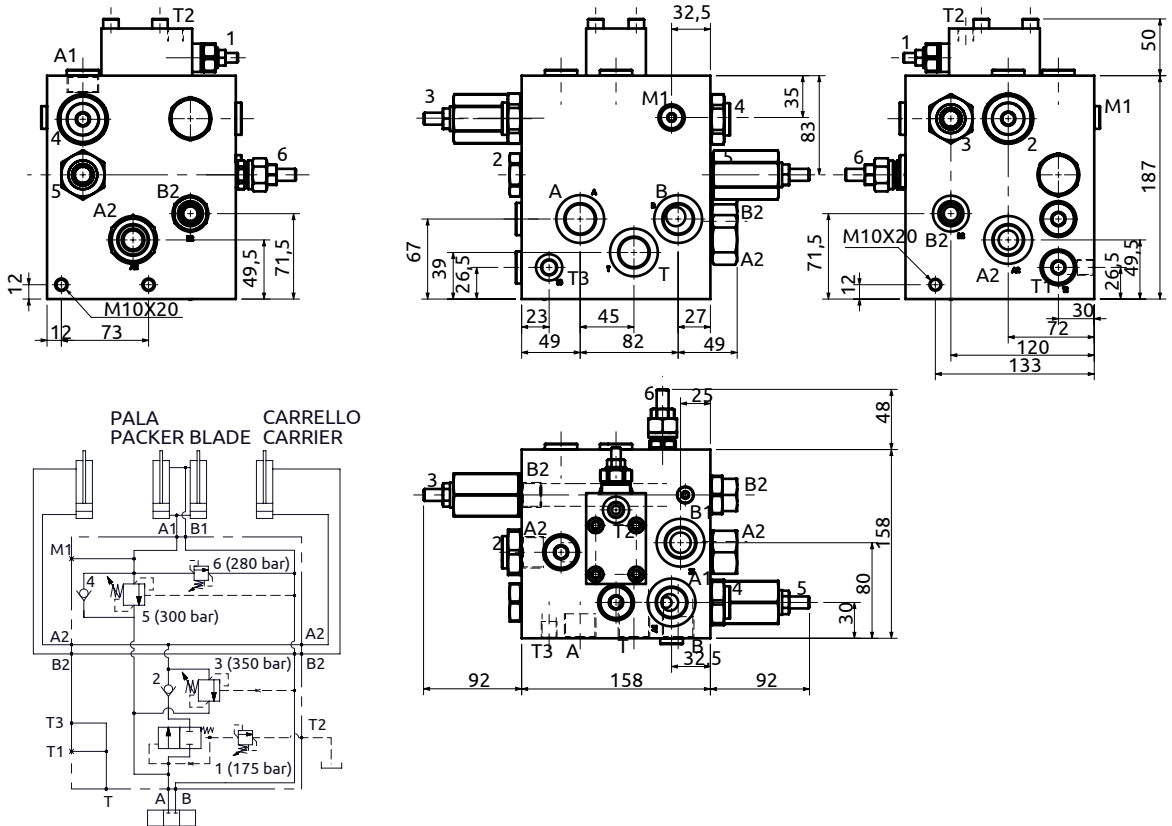

Blocco integrato per compattatori di rifiuti

Integrated block for garbage compactors



Corpo in alluminio / Aluminium body

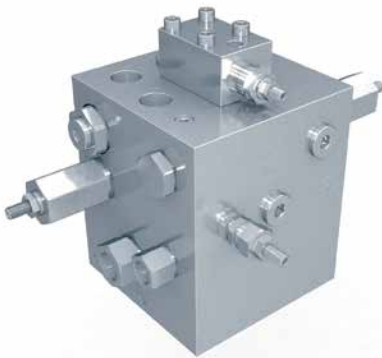

DESCRIZIONE	DESCRIPTION
Blocco integrato per il comando e il controllo dei cilindri dei compattatori di rifiuti.	Multifunction integrated block for the control of the cylinders of garbage compactors.

Codice Ordinazione	Rapporto di Pilotaggio		Campo di Taratura	Taratura Standard	Incremento per giro	Portata Massima	Pressione Max	Dimensione Porte		Peso
Ordering Code	Pilot Ratio		Pressure Range	Standard Setting	Pressure Increase	Max Flow	Max Pressure	Port Size		Weight
A600050.29.00	1	-	0-200 bar	175 bar	130 bar/turn	150 l/min	400 bar	A, A1, A2, B, B1, T	3/4"G	14.5 kg
	3	8:1	50-350 bar	350 bar	80 bar/turn					
	5	16:1	50-350 bar	300 bar	80 bar/turn					
	6	-	100-350 bar	280 bar	110 bar/turn			M1, T2, T3	1/4"G	