

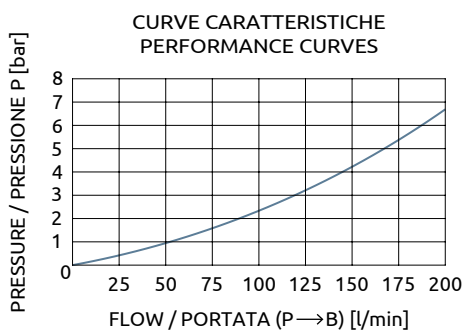

## Regolatore di portata a 3 vie compensato con elettrocomando e limitatrice di pressione / Pressure compensated flow regulator, 3 ways, with solenoid control and relief valve

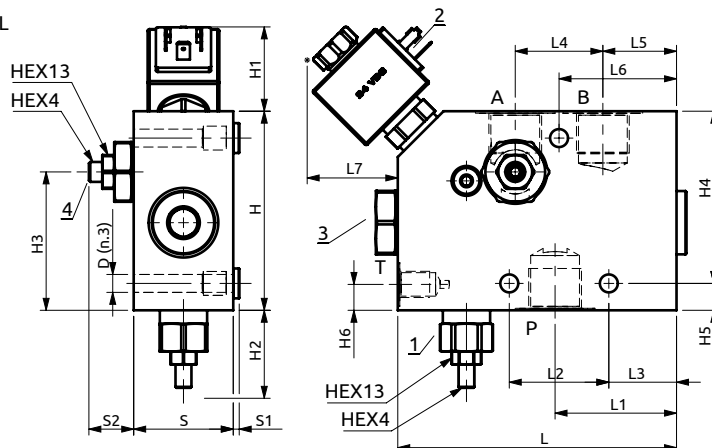
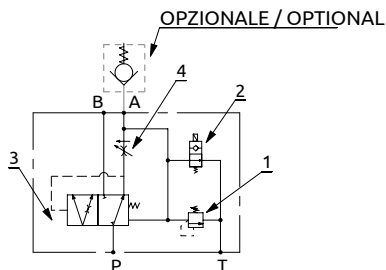

P	3/4"G	ingresso della pompa inlet flow from pump
A	3/4"G	flusso regolato regulated flow

B	3/4"G	resto del circuito rest of the circuit
T	1/4"G	drenaggio drain

Corpo in acciaio / Steel body

140	61	50	34	44	37	59	45.5	50	3	25.5	100	43	43.6	69.5	86.5	13.5	13	Ø9
L	L1	L2	L3	L4	L5	L6	L7	S	S1	S2	H	H1	H2	H3	H4	H5	H6	D

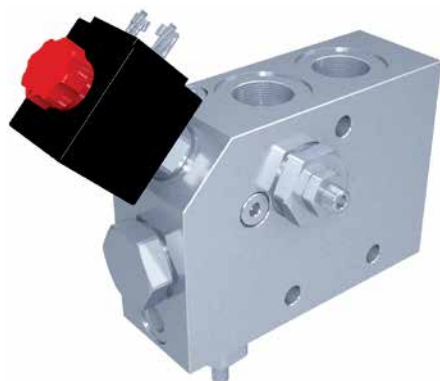

### DESCRIZIONE

Regolatore di portata compensato a 3 vie con elettrocomando e limitatrice di pressione. Per garantire un corretto funzionamento è opportuno installare su A una valvola unidirezionale da 10 bar. Elettrovalvola: 24V standard  
Max contropressione su T: 1,5 bar  
Collettore in acciaio.

### DESCRIPTION

Pressure compensated flow regulators, 3 ways, with solenoid control and relief valve. In order to archive the connect working it's appropriate to mount a check valve (setting: almost 10 bar). Solenoid: standard 24V  
Max back-pressure in T: 1.5 bar  
Body made of steel.

Codice Ordinazione	Pressione Max di Lavoro	Portata Max all'ingresso	Portata Max Regolata sul Prioritario	Incremento per giro di Regolazione	Campo di Taratura	Taratura Standard	Incremento per giro	Peso
Ordering Code	Max Working Pressure	Max Inlet Flow	Max Regulated Flow in A	Increase per Turn	Pressure Range	Standard Setting	Pressure Increase	Weight
A130603.01.00	350 bar	200 l/min	140 l/min	20 bar/turn	10-150 bar	120 bar	87 bar/turn	5.1 kg
A130603.02.00	350 bar	200 l/min	140 l/min	20 bar/turn	100-350 bar	200 bar	150 bar/turn	5.1 kg