

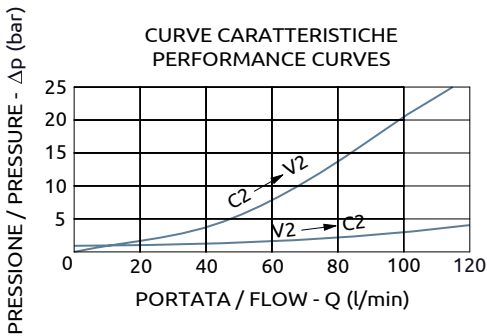

Valvola controllo rotazione  
Rotation control valve

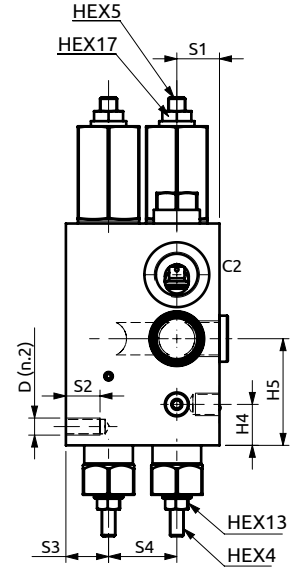
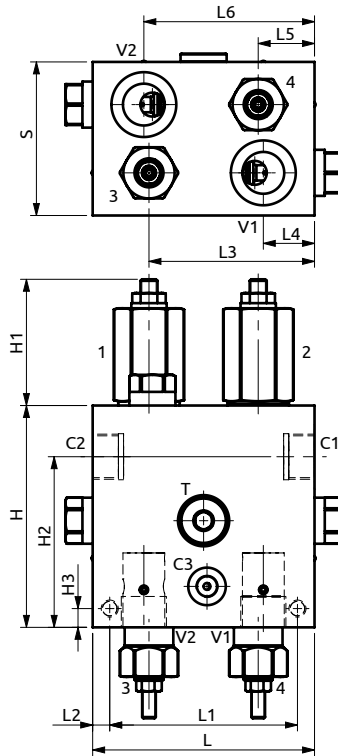
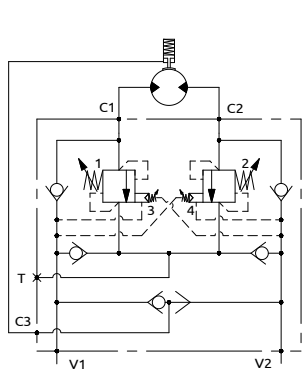

Corpo in alluminio / Aluminium body

A080602.01.00	130	110	10	97	30	33	100	90	25	20	25	40	130	~76	100	11	24	62.5	M10
COD.	L	L1	L2	L3	L4	L5	L6	S	S1	S2	S3	S4	H	H1	H2	H3	H4	H5	D



DESCRIZIONE

La valvola assicura il controllo dinamico della rotazione e della pressione in spunto o in caso di contro rotazione. L'olio viene scaricato sul ramo opposto grazie alle valvole di non ritorno integrate nel blocco. L'attacco T permette di compensare eventuali perdite d'olio per drenaggio del motore. Tramite C3 e la selettoria interna la pressione sul ramo V1 o V2 viene inviata al freno per la sua apertura, che deve avvenire in anticipo al pilotaggio valvola.

DESCRIPTION

The valve allows the dynamic control of the load rotation and to limit the inlet pressure during the starting or in case of reverse movement. The port T can be used to compensated any drain of oil of the motor. The pressure on V1 or V2 is directed by the shuttle valve to the spring brake for brake releasing. The brake must open in advance to the valve piloting.

CODICE ORDINAZIONE  
PIOMBATURA

SEALING ORDERING  
CODE

916003 - 916005

Codice Ordinazione	Rapporto di Pilotaggio	Campo di Taratura	Taratura Standard	Incremento per giro	Portata Massima	Pressione Max	Dimensione Porte	Peso		
Ordering Code	Pilot Ratio	Pressure Range	Standard Setting	Pressure Increase	Max Flow	Max Pressure	Port Size	Weight		
A080602.01.00	7.6:1	60-210 bar	1-2	180 bar	40 bar/turn	120 l/min	350 bar	V1, V2, C1, C2	3/4"G	5.8 kg
			3-4	180 bar				T	1/2"G	
									C3	