

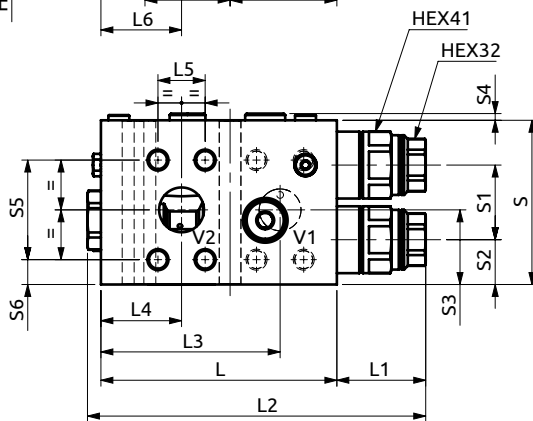

Valvola di blocco bilanciata doppia flangiabile con circuito rigenerativo
Flangeable dual overcenter valve with regenerative circuit

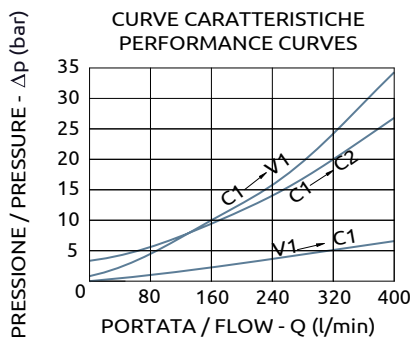
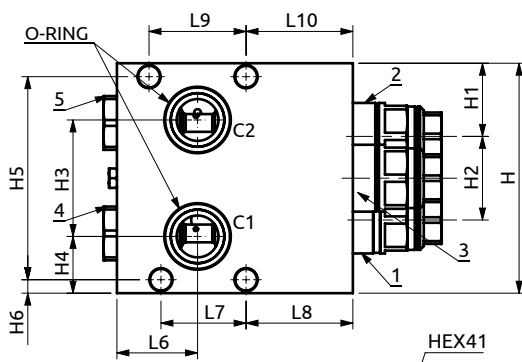
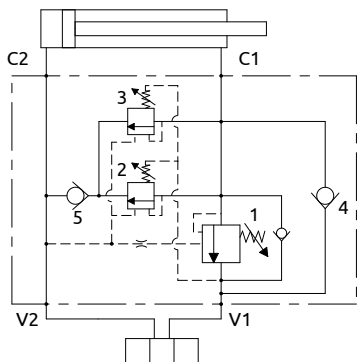

Corpo in acciaio / Steel body

158	59.5	226.5	120	54	31.6	54	57	71.5	65	71.5	110	50	30	50	4.5	66.7	16.65	154	49	56	78	38	136	9	SAE SEAL 1-1/4" 75 SH
L	L1	L2	L3	L4	L5	L6	L7	L8	L9	L10	S	S1	S2	S3	S4	S5	S6	H	H1	H2	H3	H4	H5	H6	O-RING



DESCRIZIONE	DESCRIPTION
<p>La valvola oltre alle normali funzioni delle valvole di blocco permette di sommare l'olio scaricato dal lato stelo alla portata della pompa, permettendo di velocizzare l'uscita stelo. Durante lo sfilo la spinta del cilindro equivale alla sola pressione agente sulla sezione dello stelo.</p>	<p>The valve combines the normal functions of the overcenter valves with the regenerative function, adding the return flow from the rod side to the pump flow, to reduce the extension time. During the extension, the thrust of the cylinder matches only the pressure operating on the rod section.</p>

Codice Ordinazione	Rapporto di Pilotaggio	Campo di Taratura	Taratura Standard	Incremento per giro	Portata Massima	Pressione Max	Dimensione Porte	Peso
Ordering Code	Pilot Ratio	Pressure Range	Standard Setting	Pressure Increase	Max Flow	Max Pressure	Port Size	Weight
A078590.01.00	6:1	1 200-480 bar 2-3 120-360 bar	480 bar 250 bar	95 bar/turn 60 bar/turn	400 l/min	500 bar	V1, V2 C1, C2 1"1/4 SAE6000 Ø28	18.8 kg