

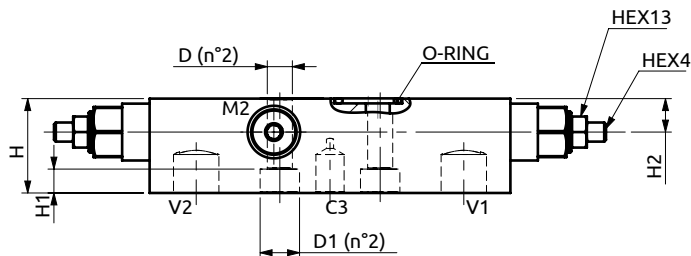

Valvola di blocco doppia serie 165 flangiabile per motori idraulici
 Dual overcenter valve "165 series", flangeable for hydraulic motors

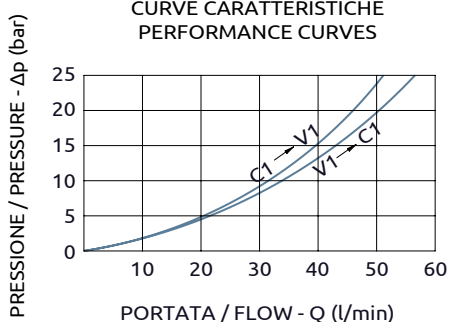
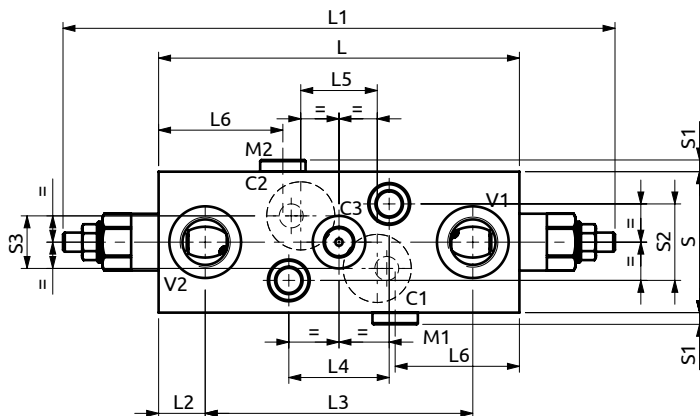
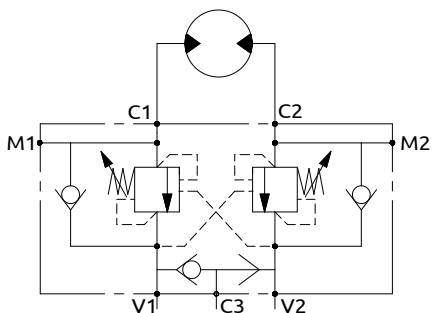

Corpo in alluminio / Aluminium body

B070481.50.00	151	242 max	19.5	112	42	32	52	59	5	32	22	39.5	10	14	Ø10.5	Ø16.5	OR 3093	23.47x2.62
COD.	L	L1	L2	L3	L4	L5	L6	S	S1	S2	S3	H	H1	H2	D	D1	O-RING	



DESCRIZIONE	DESCRIPTION
Valvola di blocco bilanciata doppia con flangiatura per motori danfoss OMS/OMSW OMSS.	Dual flangeable overcenter valve for danfoss motors OMS/OMSW OMSS.

CODICE ORDINAZIONE PIOMBATURA	SEALING ORDERING CODE
	916003

Codice Ordinazione	Rapporto di Pilotaggio	Campo di Taratura	Taratura Standard	Incremento per Giro	Portata Massima	Pressione Max	Dimensione Porte		Peso
Ordering Code	Pilot Ratio	Pressure Range	Standard Setting	Pressure Increase	Max Flow	Max Pressure	Port Size		Weight
B070481.50.00	4.2:1	100-350 bar	350 bar	135 bar/turn	60 l/min	350 bar	V1, V2	1/2"G	1.1 kg
							C3, M1, M2	1/4"G	
							C1, C2	Ø10	