

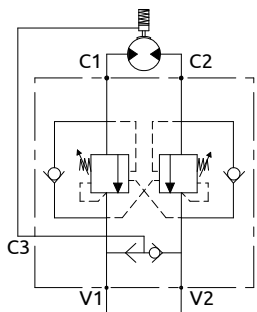

Valvola di blocco bilanciata doppia serie 165 flangiabile per motori idraulici  
 Dual overcenter valve "165 series" flangeable for hydraulic motors



PRESSIONE / PRESSURE - Δp (bar)

CURVE CARATTERISTICHE  
 PERFORMANCE CURVES

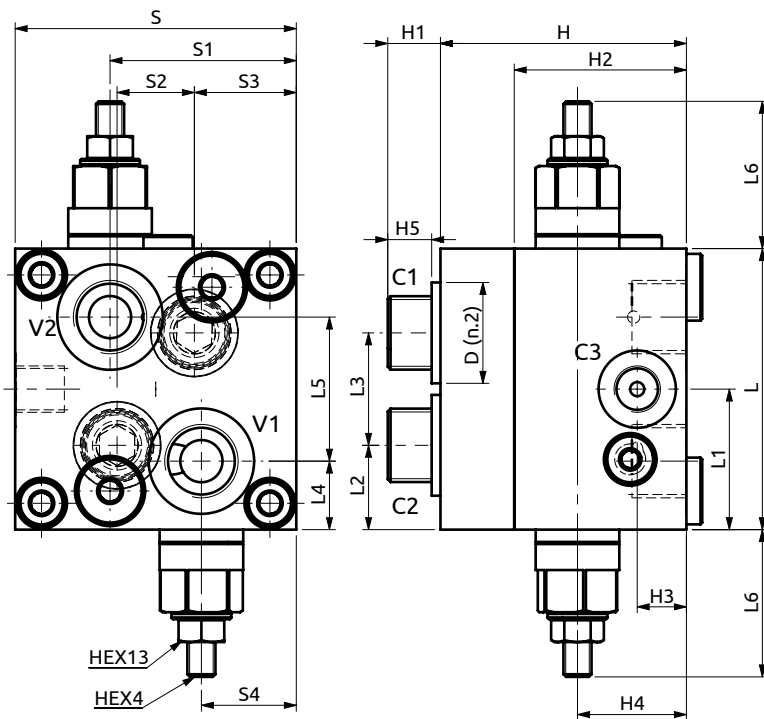
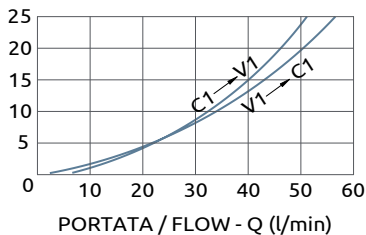

Corpo in alluminio / Aluminium body

80	40	24	32	19.5	41	~42	80	53	22	29	27	70	15	49	14	31	12.5	Ø28.7
L	L1	L2	L3	L4	L5	L6	S	S1	S2	S3	S4	H	H1	H2	H3	H4	H5	D



DESCRIZIONE	DESCRIPTION
Valvola di blocco bilanciata doppia con flangiatura per motori danfoss OMS/OMSW OMSS.	Danfoss OMS/OMSW OMSS. Dual flangeable overcenter valve for danfoss motors OMS/OMSW OMSS.
CODICE ORDINAZIONE PIOMBATURA	SEALING ORDERING CODE
916003	

Codice Ordinazione	Rapporto di Pilotaggio	Campo di Taratura	Taratura Standard	Incremento per giro	Portata Massima	Pressione Max	Dimensione Porte		Peso
Ordering Code	Pilot Ratio	Pressure Range	Standard Setting	Pressure Increase	Max Flow	Max Pressure	Port Size		Weight
B070481.27.00	4.2:1	60-220 bar	190 bar	135 bar/turn	60 l/min	350 bar	V1, V2, C1, C2	1/2" G	1.5 kg
							C3	1/4" G	