

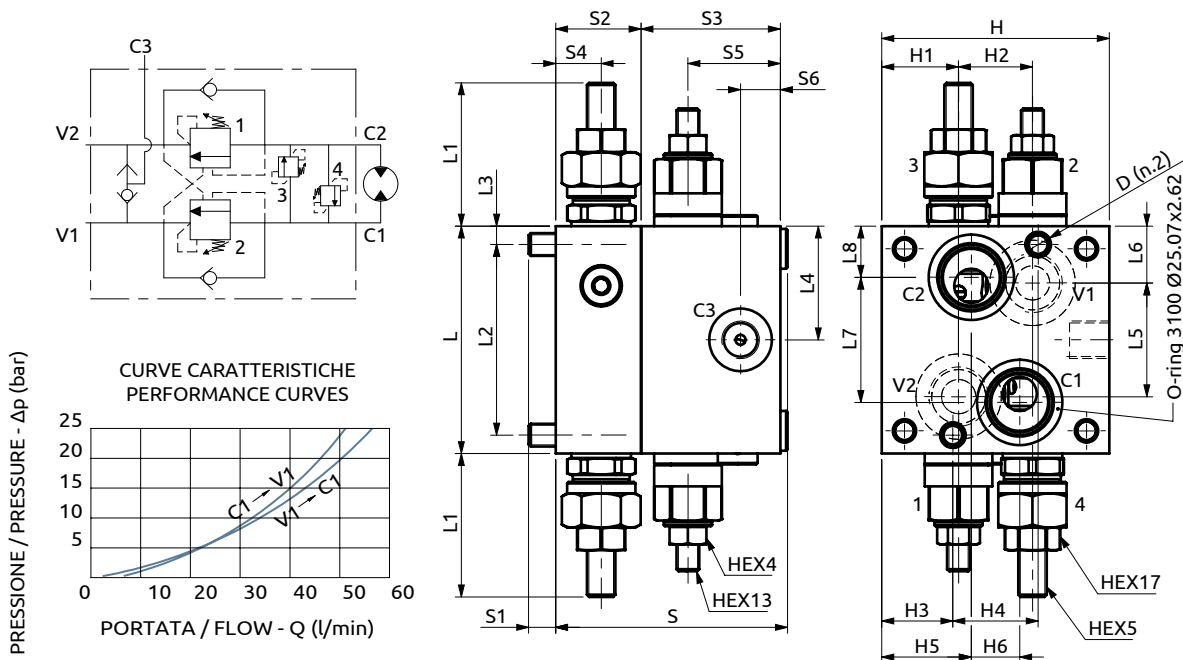

Valvola di blocco bilanciata doppia serie 165 flangiabile per motori idraulici
 Dual overcenter valve "165 series" flangeable for hydraulic motors



Corpo in alluminio / Aluminium body

80	~51	67	6.5	40	40	20	44	18	81.5	9.5	30	49	16	32.5	14	80	27	26	25	30	31,5	17	M8
L	L1	L2	L3	L4	L5	L6	L7	L8	S	S1	S2	S3	S4	S5	S6	H	H1	H2	H3	H4	H5	H6	D



DESCRIZIONE	DESCRIPTION
Valvola di blocco bilanciata doppia con valvola di massima doppia incrociata flangiata con bulloni per motori idraulici DINAMICOIL.	Dual overcenter valve with dual flangeable relief valve cross-line for DINAMICOIL machines.

CODICE ORDINAZIONE PIOMBATURA	SEALING ORDERING CODE
916003 - 916005	

Codice Ordinazione	Rapporto di Pilotaggio	Campo di Taratura	Taratura Standard	Incremento per Giro	Portata Massima	Pressione Max	Dimensione Porte	Peso
Ordering Code	Pilot Ratio	Pressure Range	Standard Setting	Pressure Increase	Max Flow	Max Pressure	Port Size	Weight
B070481.26.00	4.2:1	1-2	60-220 Bar	200 Bar	135 Bar/turn	60 L/min	V1, V2/c1, C2	1/2" g/Ø19
	-	3-4	100-350 Bar	130 Bar	110 Bar/turn		C3	