

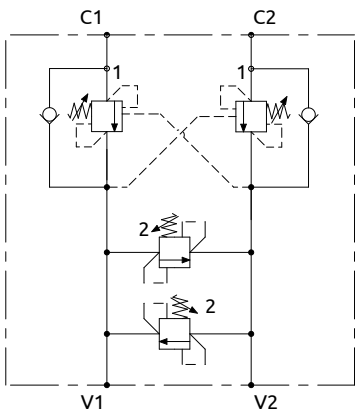

Valvola di bilanciamento doppio effetto, serie 165  
Dual overcenter valve "165 series"

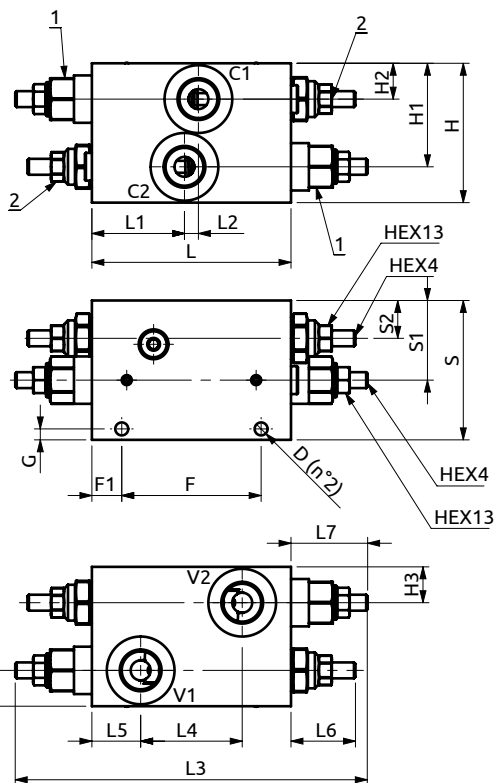

CURVE CARATTERISTICHE  
PERFORMANCE CURVES

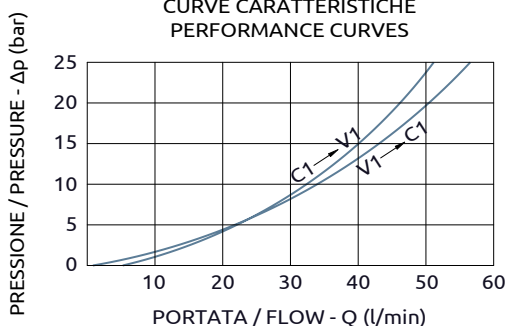

Corpo in acciaio / Steel body

<b>A070461.59.00</b>	100	46.5	7	177	51	24.5	32.4	38.5	70	38	19	70	51	18	18	70	15	5.5	Ø6.5
<b>COD.</b>	L	L1	L2	L3	L4	L5	L6	L7	S	S1	S2	H	H1	H2	H3	F	F1	G	D



DESCRIZIONE	DESCRIPTION
Valvola di blocco bilanciata doppia con valvola di massima doppia incrociata.	Dual overcenter valve with dual relief valve cross-line.
<b>CODICE ORDINAZIONE PIOMBATURA</b>	<b>SEALING ORDERING CODE</b>
916003	

Codice Ordinazione	Rapporto di Pilotaggio	Campo di Taratura	Taratura Standard	Incremento per Giro	Portata Massima	Pressione Max	Dimensione Porte	Peso
Ordering Code	Pilot Ratio	Pressure Range	Standard Setting	Pressure Increase	Max Flow	Max Pressure	Port Size	Weight
A070461.59.00	4.25:1	1	150-450 bar	425 bar	135 bar/turn	60 l/min	1/2"G	3.5 kg
		2	50-170 bar	170 bar	50 bar/turn			