

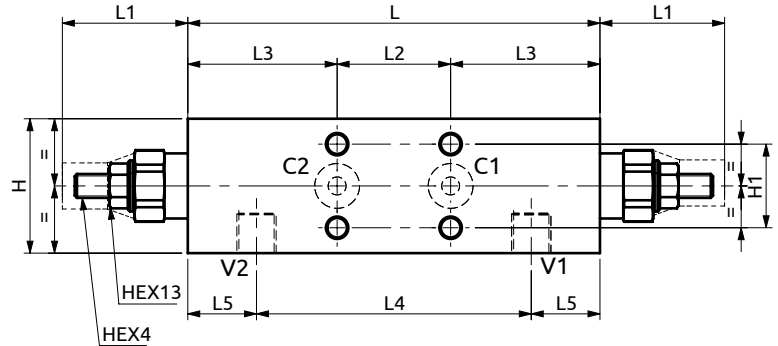

## Valvola di blocco bilanciata doppia flangiabile serie 140

### Flangeable dual overcenter valve "140 series"

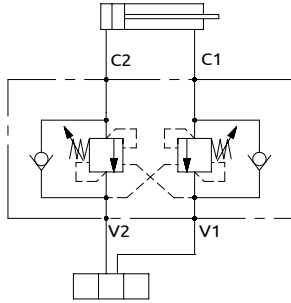

PRESSIONE / PRESSURE -  $\Delta p$  (bar)

CURVE CARATTERISTICHE  
PERFORMANCE CURVES

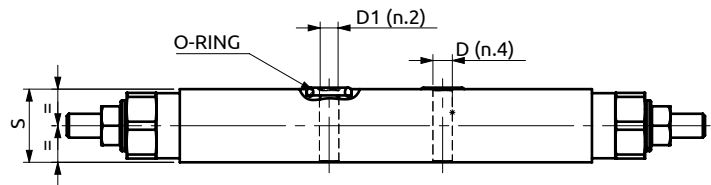
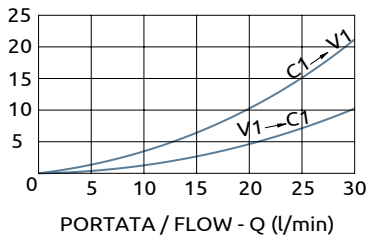

Corpo in acciaio / Steel body

138	~42	38	50	92	23	24.5	45	28	Ø6.5	Ø6	OR 112 Ø9.92x2.62
L	L1	L2	L3	L4	L5	S	H	H1	D	D1	O-RING



CODICE ORDINAZIONE  
PIOMBATURA

SEALING ORDERING  
CODE

916003

#### DESCRIZIONE

La valvola permette il flusso libero da V1>C1 o V2>C2 e il controllo nel verso opposto tramite l'azione della pressione di pilotaggio. Assicura il blocco del carico con distributore in neutro o a pompa ferma (trafilamento max. 5 gocce/min) e permette di scaricare i picchi di pressione se la spola del distributore è a centro aperto. Tarare ad almeno 1,3 volte la pressione massima indotta dal carico. Eventuali contropressioni sullo scarico aumentano la pressione di taratura e di pilotaggio richiesta per pilotare la valvola.

#### DESCRIPTION

The valve allows free flow from V1>C1 or V2>C2 and the control in the opposite direction. The load is locked when the spool valve is in neutral position or the pump is not running (max leakage 5 drops/min). Peaks of pressure can be relieved only with open centre spool valves. The valve must be set at 1,3 times the max. load induced pressure. Back pressure downstream the valve increases the setting and the requested pilot pressure.

Codice Ordinazione	Rapporto di Pilotaggio	Campo di Taratura	Taratura Standard	Incremento per giro	Portata Massima	Pressione Max	Dimensione Porte	Peso
Ordering Code	Pilot Ratio	Pressure Range	Standard Setting	Pressure Increase	Max Flow	Max Pressure	Port Size	Weight
A070281.22.00	4.1:1	100-350 bar	300 bar	180 bar/turn	30 l/min	500 bar	1/4"G	1.1 kg