

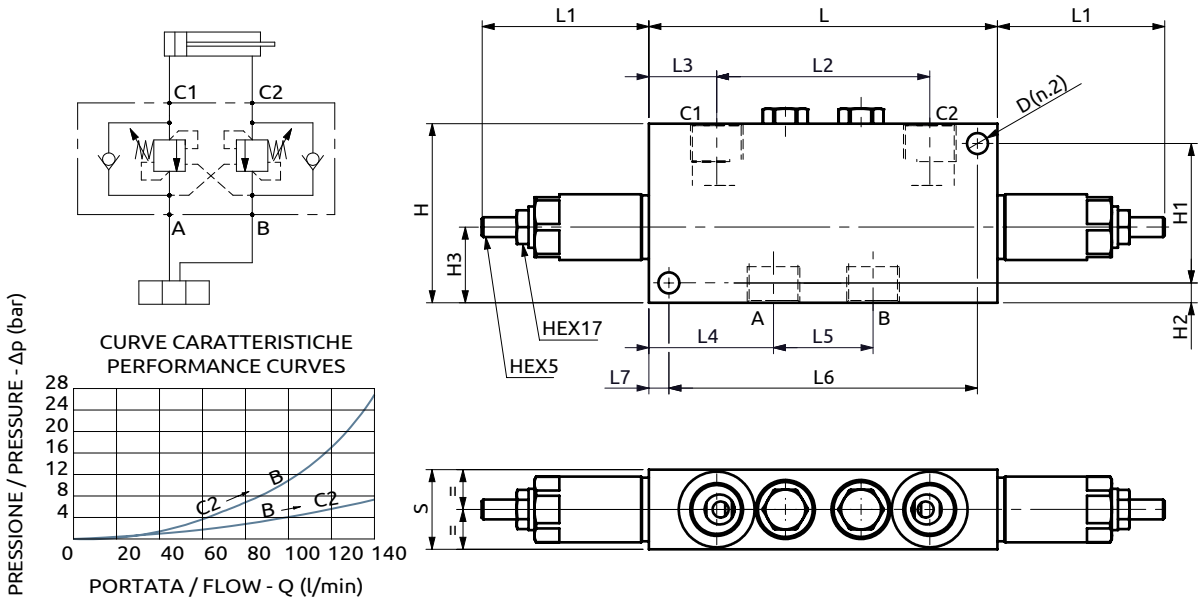

Valvola di blocco bilanciata doppia in linea serie BR Dual overcenter valve in line "BR series"



PRESSIONE / PRESSURE - Δp (bar)

CURVE CARATTERISTICHE
PERFORMANCE CURVES

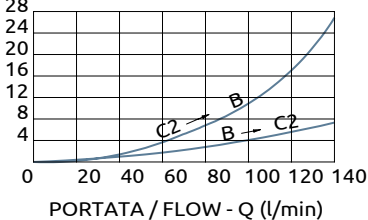

*Corpo in acciaio / Steel body

175	~66	107	34	62.5	50	155	10	40	90	70	10	38	Ø10.5
L	L1	L2	L3	L4	L5	L6	L7	S	H	H1	H2	H3	D

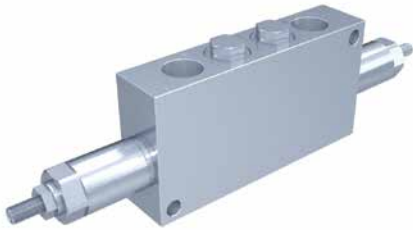

CODICE ORDINAZIONE
PIOMBATURA

SEALING ORDERING
CODE

916005

DESCRIZIONE

La valvola permette il flusso libero da A>C1 o B>C2 e il controllo nel verso opposto tramite l'azione della pressione di pilotaggio. Assicura il blocco del carico con distributore in neutro o a pompa ferma (trafilamento max. 5 gocce/min) e permette di scaricare i picchi di pressione se la spola del distributore è a centro aperto. Tarare ad almeno 1,3 volte la pressione massima indotta dal carico. Eventuali contropressioni sullo scarico aumentano la pressione di taratura e di pilotaggio richiesta per pilotare la valvola.

DESCRIPTION

The valve allows free flow from A>C1 or B>C2 and the control in the opposite direction. The load is locked when the spool valve is in neutral position or the pump is not running (max leakage 5 drops/min). Peaks of pressure can be relieved only with open centre spool valves. The valve must be set at 1,3 times the max. load induced pressure. Back pressure downstream the valve increases the setting and the requested pilot pressure.

Ordinazione	Pilotaggio	Taratura	Standard	Per Giro	Massima	Max	Porte	Peso
Ordering Code	Pilot Ratio	Pressure Range	Standard Setting	Pressure Increase	Max Flow	Max Pressure	Port Size	Weight
* A070600.11.00	4.4:1	100-350 Bar	300 Bar	90 Bar/turn	140 L/min	500 Bar	3/4" g	4.6 Kg
* A070600.12.00	8.2:1	100-400 Bar	350 Bar	90 Bar/turn	140 L/min	500 Bar	3/4" g	4.6 Kg
B070600.11.00	4.4:1	100-350 Bar	300 Bar	90 Bar/turn	140 L/min	350 Bar	3/4" g	4.6 Kg
B070600.12.00	8.2:1	100-400 Bar	350 Bar	90 Bar/turn	140 L/min	350 Bar	3/4" g	4.6 Kg