

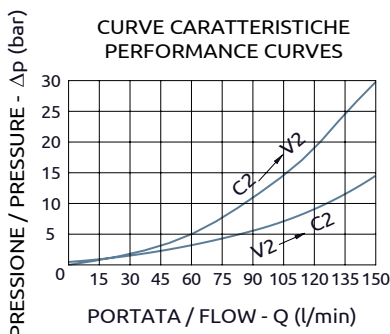

Valvola in linea per escavatori serie EMM 210 sinistra  
 Valve for earth moving machines "EMM 210 series" sx

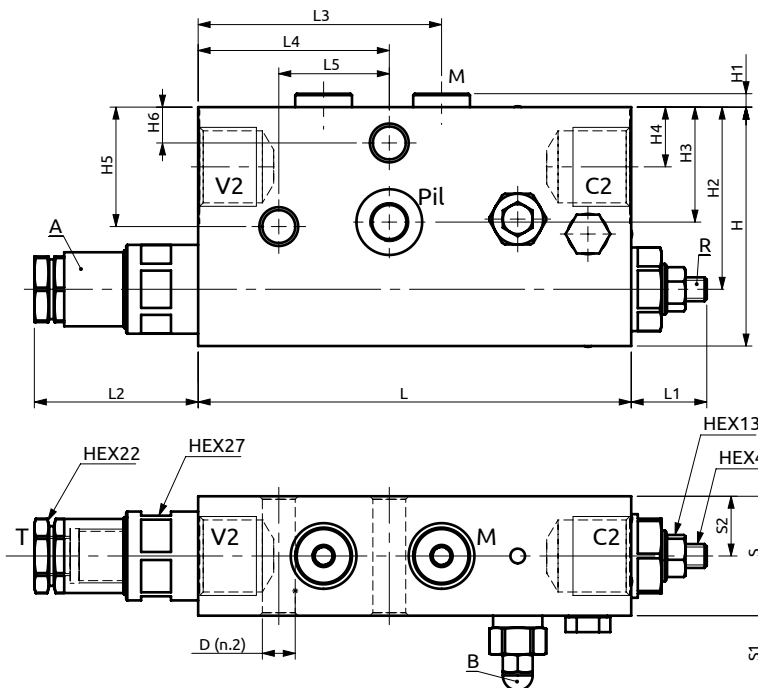
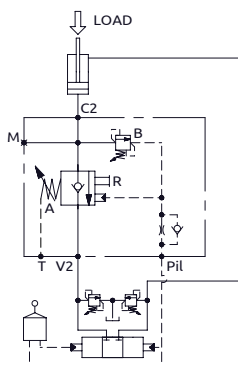

Corpo in acciaio / Steel body

<b>A060650.02.00</b>	145	~25	55	81.5	64	37	40	25	20	80	4.5	61	38.5	20	40	12	Ø11
<b>COD.</b>	L	L1	L2	L3	L4	L5	S	S1	S2	H	H1	H2	H3	H4	H5	H6	D

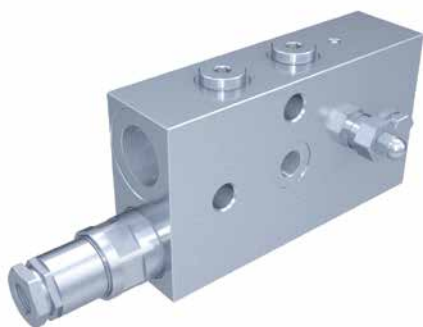

CODICE ORDINAZIONE  
 PIOMBATURA

SEALING ORDERING  
 CODE

916003

DESCRIZIONE	DESCRIPTION
<p>Collegare all'impianto come da schema. Il pilotaggio della valvola è prelevato dai manipolatori di comando distributore e la valvola permette: il flusso libero da V2 verso C2, il sostentamento del carico con distributore in neutro o pompa ferma, controllo della discesa a valvola pilotata e protezione contro sovrappressioni nel cilindro. L'attacco T deve essere collegato direttamente a scarico.</p>	<p>To be connected as shown. The pilot signal is taken from the machine manipulators, the valve allows: free flow from V2 to C2, to hold the load with spool in neutral position or with the pump not running, controlled movement when pilot pressure is applied, relief function against overpressure in the cylinder. T port must be connected directly to the tank.</p>

Codice Ordinazione	Campo di Taratura		Taratura Standard	Incremento per giro	Portata Massima	Pressione Max	Dimensione Porte		Peso
Ordering Code	Pressure Range		Standard Setting	Pressure Increase	Max Flow	Max Pressure	Port Size		Weight
A060650.02.00	A	7-19.5 bar	7.5 bar	3 bar/turn	150 l/min	500 bar	V2, C2	3/4"G	3.4 kg
	B	200-400 bar	350 bar	215 bar/turn			Pil, T	1/4"G	
							M	1/4"G	