

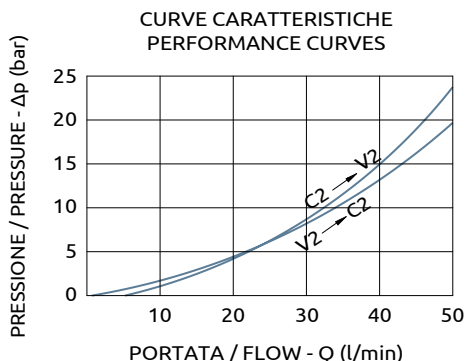

Valvola di bilanciamento semplice effetto, serie 165 flangiabile
Flangeable single overcenter valve "165 series"

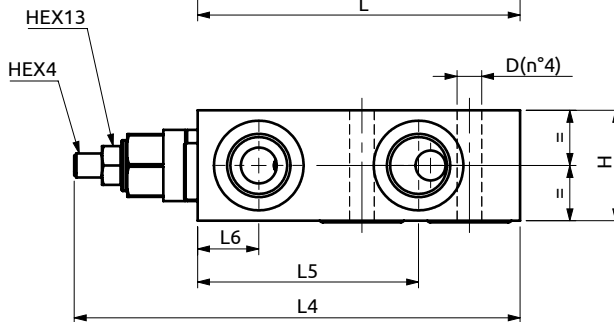
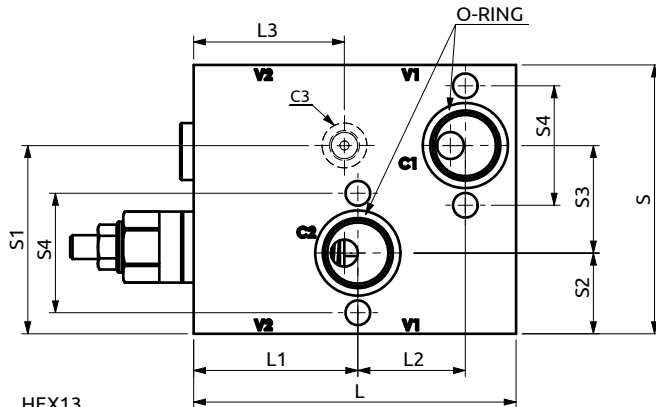
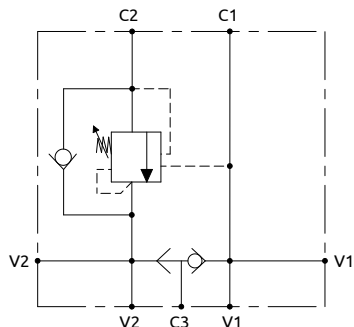

Corpo in acciaio / Steel body

A060481.10.00	108	55	36	50.5	~149.3	74	20.5	90	63	27	36	40	37	Ø8.25	OR 3093 Ø23.47x2.62
COD.	L	L1	L2	L3	L4	L5	L6	S	S1	S2	S3	S3	H	D	O-RING



DESCRIZIONE	DESCRIPTION
Valvola di blocco bilanciata semplice con flangiatura per motori Danfoss OMR, OMP e white series HS e HR.	Single flangeable overcenter valve for danfoss motors OMR OMP and white series HS, HP.

CODICE ORDINAZIONE PIOMBATURA	SEALING ORDERING CODE
	916003

Codice Ordinazione	Rapporto di Pilotaggio	Campo di Taratura	Taratura Standard	Incremento per Giro	Portata Massima	Pressione Max	Dimensione Porte		Peso
Ordering Code	Pilot Ratio	Pressure Range	Standard Setting	Pressure Increase	Max Flow	Max Pressure	Port Size		Weight
A060481.10.00	4.25:1	100-350 bar	300 bar	135 bar/turn	50 l/min	300 bar	V1-V2	1/2"G	2.5 kg
							C1-C2	Ø9	
							C3	1/8"G	