

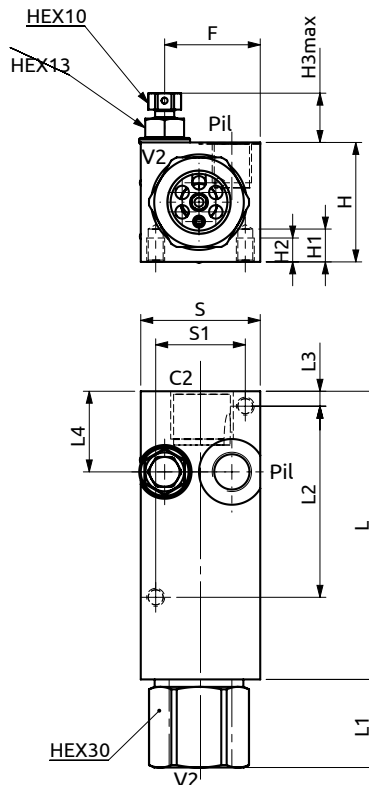

Valvola di bilanciamento semplice effetto, serie 165
Single overcenter "165 series"

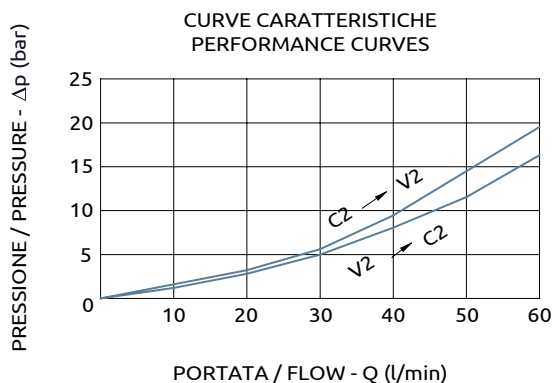
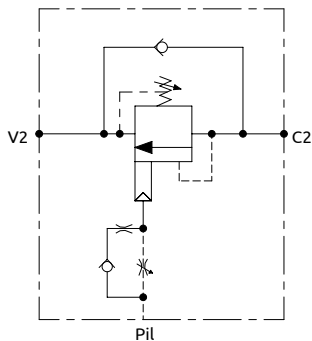

Corpo in acciaio / Steel body

A060461.15.00	96.5	29.5	64	5	27	40	30	40	11	8	21	32	M6
COD.	L	L1	L2	L3	L4	S	S1	H	H1	H2	H3	F	D



DESCRIZIONE	DESCRIPTION
Collegare all'impianto come da schema. Il pilotaggio della valvola è prelevato dai manipolatori di comando distributore e la valvola permette: il flusso libero da V2 verso C2, il sostentamento del carico con distributore in neutro o pompa ferma, controllo della discesa a valvola pilotata e protezione contro sovrappressioni nel cilindro.	To be connected as shown. The pilot signal is taken from the machine manipulators, the valve allows: free flow from V2 to C2, to hold the load with spool in neutral position or with the pump not running, controlled movement when pilot pressure is applied, relief function against overpressure in the cylinder.

Codice Ordinazione	Rapporto di Pilotaggio	Campo di Taratura	Taratura Standard	Incremento per giro	Portata Massima	Pressione Max	Dimensione Porte		Peso
Ordering Code	Pilot Ratio	Pressure Range	Standard Setting	Pressure Increase	Max Flow	Max Pressure	Port Size		Weight
A060461.15.00	4.25:1	140-320 bar	280 bar	190 bar/turn	60 l/min	350 bar	V2-C2	1/2"G	1.14 kg
							Pil	1/4"G	