

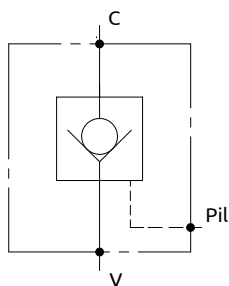

## Valvola di blocco a cartuccia pilotata Pilot operated check valve cartridge type

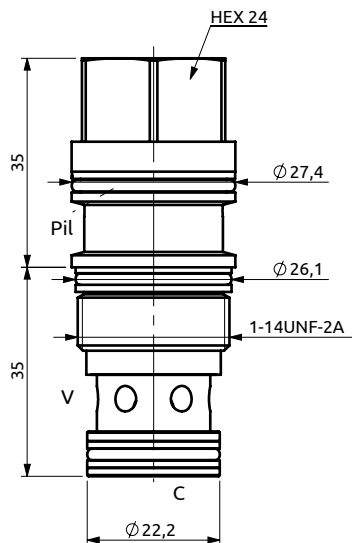

CURVE CARATTERISTICHE  
PERFORMANCE CURVES

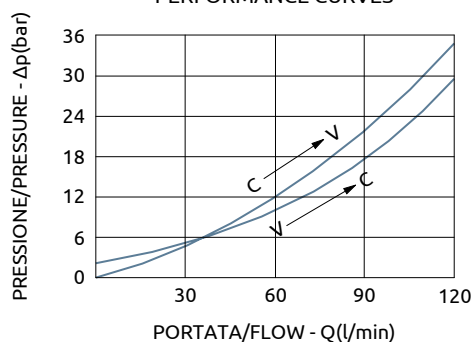

CODICE SEDE	CAVITY CODE
HBS.95.S.03A (Pag. 99.08.01)	



DESCRIZIONE	DESCRIPTION
Permette il flusso libero da V verso C. Idonea al sostentamento di un carico, non al controllo discesa.	The valve allows free flow from V to C. Suitable to hold a load not to control a load lowering.
COPPIA DI SERRAGGIO	INSTALLATION TORQUE
60 Nm	

Codice Ordinazione	Rapporto di Pilotaggio	Pressione d'inizio Apertura	Portata Massima	Pressione Max	Peso
Ordering Code	Pilot Ratio	Cracking Pressure	Max Flow	Max Pressure	Weight
C052201.01.00	4.5:1	2 bar	120 l/min	350 bar	0.25 kg