

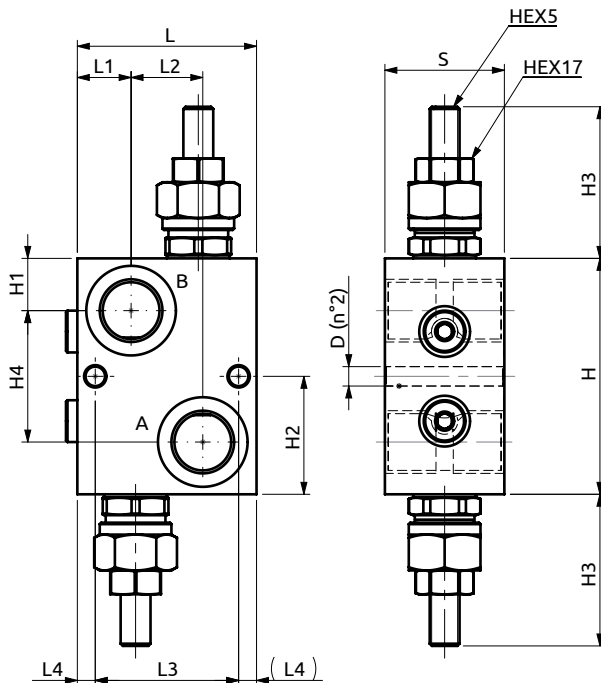

Valvola limitatrice di pressione doppia incrociata
Dual cross-over relief valve

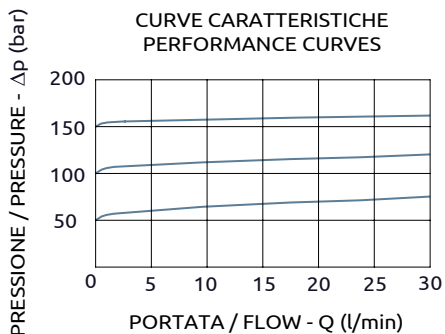
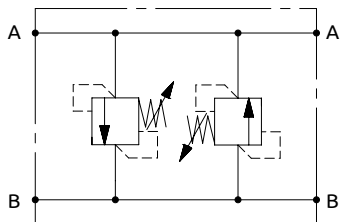

Corpo in alluminio / Aluminium body

B010402.01.00	60	18	24	48	6	40	85	20.5	42.5	~51	44	Ø6.5
B010402.02.00	60	18	24	48	6	40	79	17.5	39.5	~51	44	Ø6.5
COD.	L	L1	L2	L3	L4	S	H	H1	H2	H3	H4	D



DESCRIZIONE	DESCRIPTION
Valvola limitatrice di pressione doppia incrociata con tenuta ad otturatore, con funzione di protezione del circuito da sovrapressioni. Disponibile con due differenti campi di taratura.	Dual relief valve in compact steel construction poppet type, for overload protection. Two setting ranges available.
CODICE ORDINAZIONE PIOMBATURA	SEALING ORDERING CODE
916005	

Codice Ordinazione	Campo di Taratura	Taratura Standard	Incremento per Giro	Portata Massima	Pressione Max	Dimensione Porte	Peso
Ordering Code	Pressure Range	Standard Setting	Pressure Increase	Max Flow	Max Pressure	Port Size	Weight
B010402.01.00	40-150 bar	120 bar	57 bar/turn	30 l/min	250 bar	1/2"G	0.7 kg
B010402.02.00	40-150 bar	80 bar	25 bar/turn	30 l/min	250 bar	1/2"G	0.7 kg